



# SM-501 SERIES DUCT SMOKE DETECTORS

## **PRODUCT APPLICATION**

The SM-501 Series Duct Smoke Detector provides early detection of smoke and products of combustion present in air moving through HVAC ducts in Commercial, Industrial, and Residential applications. The unit is designed to prevent the re-circulation or spread of smoke by air handling systems, fans, and blowers. Complete systems may be shut down in the event of smoke detection.

The SM-501 model will operate on any one of four input voltages (230VAC, 115VAC, 24VAC, or 24VDC). The SM-501 allows up to 30 detectors to be interconnected for many common functions.

## **PRODUCT DESCRIPTION**

Continuing our history of building innovative and reliable products, the SM-501 is housed in our popular traditional compact housing. The unit provides two sets of 10 Amp form "C" alarm contacts, along with one set of 10 Amp form "C" trouble contacts for monitoring head removal and supply voltage failure.

The green pilot and red alarm visual indicators provided on the front of the SM-501 signal the operating status of the device. The green pilot LED will be extinguished when the detector head is removed or power is lost. A manual test/reset switch is located next to the visual indicators.

The SM-501 has been specially designed to allow linkage of common detector functions for up to 30 detectors. The units may be wired to use a common test/reset function, and to alarm when a single unit alarms. Also, up to 15 units with signaling devices may be interconnected to operate with a single alarm.

The SM-501 is designed and built to meet all local code requirements, as well as the NFPA and ICC standards regarding HVAC supply and return duct smoke detectors. Output terminals are provided for remote accessories such as horns, strobes, remote status indicators, and test/reset key switches or push buttons.

The SM-501 is available with either ionization or photoelectric detector heads, which are interchangeable. Air sampling is accomplished via two rear loading tubes which protrude into the duct. An exhaust tube of one standard length (7.0") is supplied in the installation kit with the duct smoke unit. Once the duct width has been determined, the air intake sampling tube must be ordered. Sampling tubes are supplied in standard lengths (1.0', 2.5', 5.0', and 10.0'), and are cut to size to fit the duct. Mounting the duct smoke detector is accomplished by the use of a template and four sheet metal screws, as provided. Mounting can be achieved without the removal of the clear cover, which is secured by four captive screws.

## **FEATURES**

- ❖ Operating voltages: 230VAC, 115VAC, 24VAC, 24VDC
- ❖ Both models listed for high temperature applications
- ❖ Interconnect up to 30 units for common functions
- ❖ UL, CUL, CSFM, and MEA Listed
- ❖ Compact Size
- ❖ Two sets of 10A form "C" alarm contacts
- ❖ One set of 10A form "C" trouble contacts
- ❖ Rugged steel back box with clear cover
- ❖ Compatible with the WP-1 weatherproof enclosure
- ❖ Easy retro-fit/upgrade of existing RW Series detectors
- ❖ Clear cover fitted with 4 captive screws
- ❖ Large terminal connection screws
- ❖ Interchangeable "Plug-In" photoelectric or ionization heads
- ❖ Easy mounting without cover removal
- ❖ Advanced detector head design yields internal dust filtering with no additional screens or filters to clean
- ❖ Over 15 remote accessories available

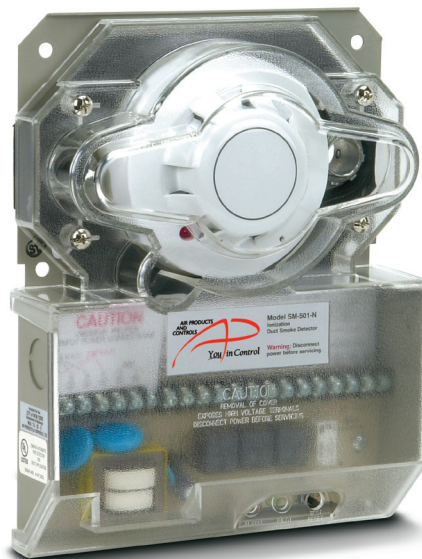

**CSFM LISTED**



**ME A ACCEPTED**

*Air Products and Controls  
is a Brand of Apollo America  
25 Corporate Drive  
Auburn Hills, MI 48326  
(248) 332-3900 Phone  
(888) 332-2241 Toll free  
(248) 332-8807 Fax  
www.ap-c.com*



*Distributed By:*



# WIRING

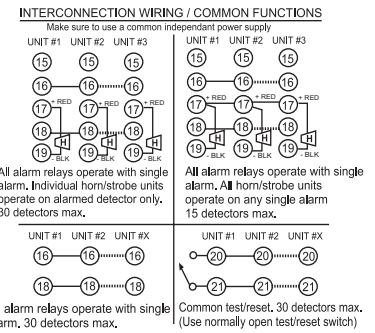
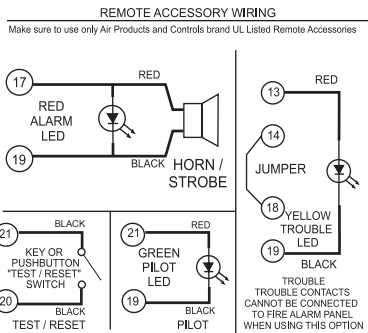
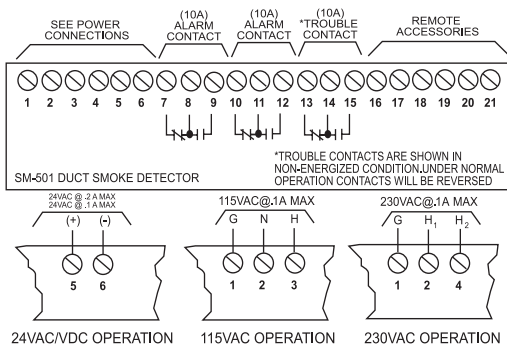

## PRODUCT SPECIFICATIONS

MODEL NUMBER:	<b>SM-501-N</b>	Ionization: 230VAC, 115VAC, 24VAC, 24VDC
	<b>SM-501-P</b>	Photoelectric: 230VAC, 115VAC, 24VAC, 24VDC
DETECTOR HEAD MODEL NUMBER:	<b>SM-501-N</b>	55000-250APO or 55000-225APO
	<b>SM-501-P</b>	55000-350APO or 55000-328APO
SAMPLING TUBES:	<b>FAST Tube</b>	Sectional sampling tube, kit fits up to 90" duct width
	<b>STS-1.0</b>	Sampling tube for 12" or less duct width
	<b>STS-2.5</b>	Sampling tube for 6" to 2.5' duct width
	<b>STS-5.0</b>	Sampling tube for 2.5' to 5.0' duct width
	<b>STS-10.0</b>	Sampling tube for 5.0' to 10.0' duct width
ACCESSORIES:	MS-Series remote accessories, WP-1 weatherproof enclosure, TG-1000 aerosol test gas, and T-PB power supplies (All available from Apollo America)	
POWER REQUIREMENTS: (without accessories)	230VAC	12.0 mA
Standby:	115VAC	25.0 mA
	24VAC	35.0 mA
	24VDC	15.0 mA
Alarm:	230VAC	16.0 mA
	115VAC	32.0 mA
	24VAC	74.0 mA
	24VDC	56.0 mA
RELAY CONTACT RATING:	Resistive load: 2 sets form "C" rated at 10 Amps @ 115VAC	
Alarm Contacts:	Resistive load: 1 set form "C" rated at 10 Amps @ 115VAC	
Trouble Contacts:	500 to 4,000 ft./min.	
AIR VELOCITY:	500 to 4,000 ft./min.	
AMBIENT TEMPERATURE:	<b>SM-501-N</b>	32°F to 158°F (0°C to 70°C)
	<b>SM-501-P</b>	32°F to 140°F (0°C to 60°C)
HUMIDITY:	85 ±5 % RH (@32 ±2°C; 86 ±3.6°F) Non-Condensing / Non-Freezing	
WIRING:	Solid or stranded: #12 to #22 AWG terminals	
APPROVALS:	UL & CUL Listed (UL268A, UROX, UROX7), File # S2829 CSFM Listed (3240-1004:108) MEA Accepted (73-92-E; VOL. 26)	
MATERIAL:	18ga. Steel backbox, clear plastic cover (Makrolon 94V-0)	
FINISH:	Grey paint	
DIMENSIONS:	9 1/8" L x 7 1/4" W x 2 1/4" H	
MAX. NET WT.:	3 1/2 lbs.	
RADIOACTIVE ELEMENT:	For <b>SM-501-N</b> (Ionization) Americium 241; 0.9 Micro-Curie Do not expose to corrosive atmospheres	
HARDWARE:	7" exhaust tube, sampling tube end cap, mounting template, and mounting hardware included	

## ENGINEERS & ARCHITECTS SPECIFICATIONS

- Air duct smoke detectors shall be Air Products and Controls Inc. SM-501 Series. For Ionization detectors the model number is **SM-501-N**. For photoelectric detectors the model number is **SM-501-P**. The detectors shall be listed by Underwriters Laboratories per UL 268A.
- The detectors shall operate at air velocities from 500 feet per minute to 4,000 feet per minute and at temperatures of no greater than 140°F (60°C).
- The duct detector housings shall be of metal construction and complete mechanical installation may be performed without removal of detector cover.
- Visual indication of alarm and power must be provided on the detector front.
- A manual reset switch shall be located on front of the device.
- Detector head shall not require additional filters or screens which must be maintained.
- The housing shall contain a detector base which will accept photoelectric or ionization detector heads.
- Terminal connections shall be of the screw type and be a minimum of #6 screw (#12 to #22 AWG compatible). Terminals shall be provided for remote pilot, remote alarm indications, strobe/horn and remote test/reset switch. All wiring must comply with local codes and regulations.
- Capability for interconnection of up to 30 units shall be provided for common functions.

**NOTICE:** The information contained in this document is intended only as a summary and is subject to change without notice. The products described have specific instructional/installation documentation, which covers various technical, approval, code, limitation and liability information. Copies of this documentation along with any general product warning and limitation documents, which also contain important information, are provided with the product and are also available from Apollo America. The information contained in all of these documents should be considered before specifying or using the products. Any example applications shown are subject to the most current enforced local/national codes, standards, approvals, certifications, and/or the authority having jurisdiction. All of these resources, as well as the specific manufacturer of any shown or mentioned related equipment, should be consulted prior to any implementation. For further information or assistance concerning the products, contact Apollo America. Apollo America reserves the right to change any and all documentation without notice.