

## **Q-AVERAGE FLANGE**

### Duct Averaging Temperature Sensor

#### FEATURES

- Durable injection-molded plastic mounting flange
- Lengths: 8', 12', 24' and 18"
- Patent Pending Quick Coupling from enclosure to sensing tube
- Patent Pending Quick Connect System eliminates wire nuts
- NTC thermistor and RTD elements available
- Compatible with all major control systems
- CE & RoHS compliant
- 5 Year Limited Warranty
- Made in USA

#### GENERAL INFORMATION

High quality Duct Averaging Temperature Sensor with an injection molded flange. Patent Pending water tight Quick Coupling allows for disconnection of the sensing tube to the enclosure, for fast installation. Sensing tube is 7mm diameter flexible aluminum tubing, and 18" 316L rigid stainless steel.

Available measuring elements interface with all major control manufacturers. Accurate interchangeable thermistors ensure low drift and are double encapsulated to guarantee the highest reliability. The Patent Pending Quick Connect system eliminates wire nuts for a faster, more reliable installation and reduces installation costs.

#### SPECIFICATIONS

Enclosure:	Injection-molded 30% glass filled nylon flange with two integrated #8 mounting holes, UL 94 HB
Connection:	2-pole AWG 22-16 / 0.35 - 1.5mm <sup>2</sup> spring-loaded, Patent Pending Quick Connect System
Probe Length:	8', 12', or 24' coiled, and 18" rigid
Probe Material:	7mm aluminum tubing, and 18" rigid 316L stainless steel
Quick Coupling:	NEMA 6P/IP68 Water tight Quick Coupling from probe to enclosure
Sensor Element:	Interchangeable NTC thermistor, 2-wire RTD Pt100, Pt1000, 2-wire RTD Ni1000-891, Ni1000-TC5, 2 wire



## SPECIFICATIONS CONT.

Number of elements: 24' has 9 sensors, 12' has 4 sensors, 8' has 4 sensors, 18" has 4 sensors

Sensor Value: NTC 10K Ohm type 2 @ 25°C / 77°F  
NTC 10K Ohm type 3 @ 25°C / 77°F  
NTC 20K Ohm @ 25°C / 77°F  
NTC 3K Ohm @ 25°C / 77°F  
RTD Pt1000 1000 Ohm @ 0°C / 32°F  
RTD Pt100 100 Ohm @ 0°C / 32°F  
RTD Ni1000-891 891 Ohm @ 0°C / 32°F  
RTD Ni1000-TC5 1000 Ohm @ 0°C / 32°F  
(Other elements on request)

Accuracy: NTC thermistor 0...70°C ± 0.2°C / 32...158°F ± 0.36°F  
Pt100 / Pt1000 Class B IEC751, ± 0.3°C / ± 0.5°F @ 0°C / 32°F  
Ni1000 DIN 43760, ± 0.5°C / ± 0.9°F @ 0°C / 32°F

Range: -40...105°C / -40...221°F

Approval: CE & RoHS compliant  
Warranty: 5 year limited warranty

## DIMENSIONS (in mm)

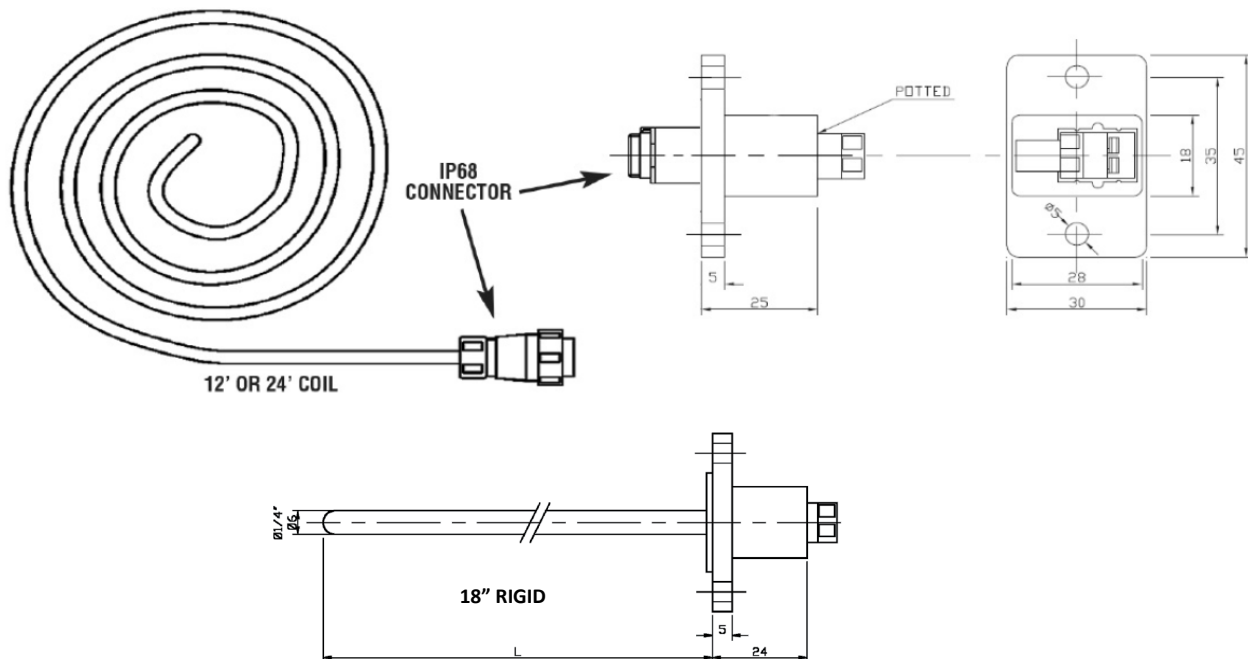

## ORDERING INFORMATION

### HOW TO BUILD A TASSERON Q-AVERAGE FLANGE PART NUMBER

Sample Part Number (THTAFA24) —Q-Duct Flange sensor with 10k Type 2 element and 24' coil.

T	H	T	A	F	A	24
Tasseron	HVAC	Temp	Average	Flange	Element	Details
					A—10K -2	18—18 Inches
					B—10K -3	08—8 feet
					C—20K	12—12 feet
					D—3K	24—24 feet
					E—Pt1000	
					F—Ni1000-891	
					G—10K-4	
					H— Pt100	
					I—4.7K	
					J—10K-3 (11K)	
					K— Ni1000-TC5	
					*Other elements available on re- quest	

# HVAC temperature measuring elements

## R/T TABLES

Temp		NTC thermistors					RTD elements			
		curve A	curve B	curve G	curve C	curve D	curve E	curve F	curve H	curve K
		NTC 10K type 2	NTC 10K type 3	NTC 10K type 4	NTC 20KOhm	NTC 3KOhm	Pt1000/B	Ni1000-891	Pt100/B	Ni1000-TC5
°C	°F	R (kOhm)	R (kOhm)	R (kOhm)	R (kOhm)	R (kOhm)	R (Ohm)	R (Ohm)	R (Ohm)	R (Ohm)
-40	-40	341.4	242.1	191.9	784.6	97.40	843	697	84.3	831
-35	-31	246.2	181.0	146.6	558.8	71.53	862	719	86.2	851
-30	-22	179.5	136.6	112.9	402.7	52.80	882	743	88.2	872
-25	-13	132.2	103.9	87.59	293.6	39.16	902	766	90.2	893
-20	-4	98.34	79.64	68.47	216.3	29.24	922	790	92.2	914
-15	5	73.73	61.54	53.91	160.7	22.04	941	815	94.1	935
-10	14	55.78	47.91	42.74	120.5	16.74	961	839	96.1	956
-5	23	42.59	37.57	34.11	91.07	12.79	980	864	98.0	978
0	32	32.82	29.66	27.40	69.40	9.856	1000	891	100.0	1000
5	41	25.52	23.57	22.14	53.33	7.663	1020	916	102.0	1022
10	50	19.97	18.85	17.99	41.28	5.999	1039	942	103.9	1045
15	59	15.75	15.17	14.72	32.18	4.729	1058	968	105.8	1068
20	68	12.51	12.28	12.09	25.28	3.754	1078	994	107.8	1091
25	77	10.00	10.00	10.00	20.00	3.000	1097	1021	109.7	1114
30	86	8.048	8.184	8.308	15.92	2.416	1117	1048	111.7	1138
35	95	6.516	6.735	6.936	12.75	1.957	1136	1075	113.6	1162
40	104	5.306	5.577	5.819	10.27	1.595	1155	1102	115.5	1186
45	113	4.345	4.641	4.904	8.320	1.307	1175	1130	117.5	1210
50	122	3.578	3.877	4.151	6.779	1.076	1194	1158	119.4	1235
55	131	2.962	3.261	3.529	5.556	0.888	1213	1187	121.3	1260
60	140	2.464	2.756	3.012	4.577	0.737	1232	1216	123.2	1285
65	149	2.060	2.340	2.582	3.788	0.616	1252	1245	125.2	1311
70	158	1.730	1.996	2.221	3.150	0.518	1271	1274	127.1	1337
75	167	1.460	1.707	1.918	2.630	0.441	1290	1304	129.0	1364
80	176	1.236	1.466	1.663	2.206	0.377	1309	1334	130.9	1390
85	185	1.051	1.264	1.446	1.857	0.324	1328	1365	132.8	1417
90	194	0.896	1.095	1.262	1.570	0.278	1347	1396	134.7	1444
95	203	0.767	0.952	1.105	1.333	0.239	1366	1427	136.6	1472
100	212	0.659	0.831	0.970	1.136	0.206	1385	1459	138.5	1500
105	221	0.569	0.728	0.855	0.972	0.179	1404	1491	140.4	1528
110	230	0.493	0.640	0.755	0.834	0.156	1423	1524	142.3	1557
115	239	0.428	0.564	0.669	0.719	0.136	1442	1556	144.2	1586
120	248	0.374	0.499	0.594	0.621	0.119	1461	1590	146.1	1615
125	257	0.327	0.443	0.529	0.539	0.105	1479	1623	147.9	1645

\* Other elements on request

Tasseron Sensors Inc.

140 Choate Circle

Montoursville, PA 17754

Tel: +1 (570) 601-1971

Fax: +1 (570) 601-1972

Email: sales@tasseronusa.com